

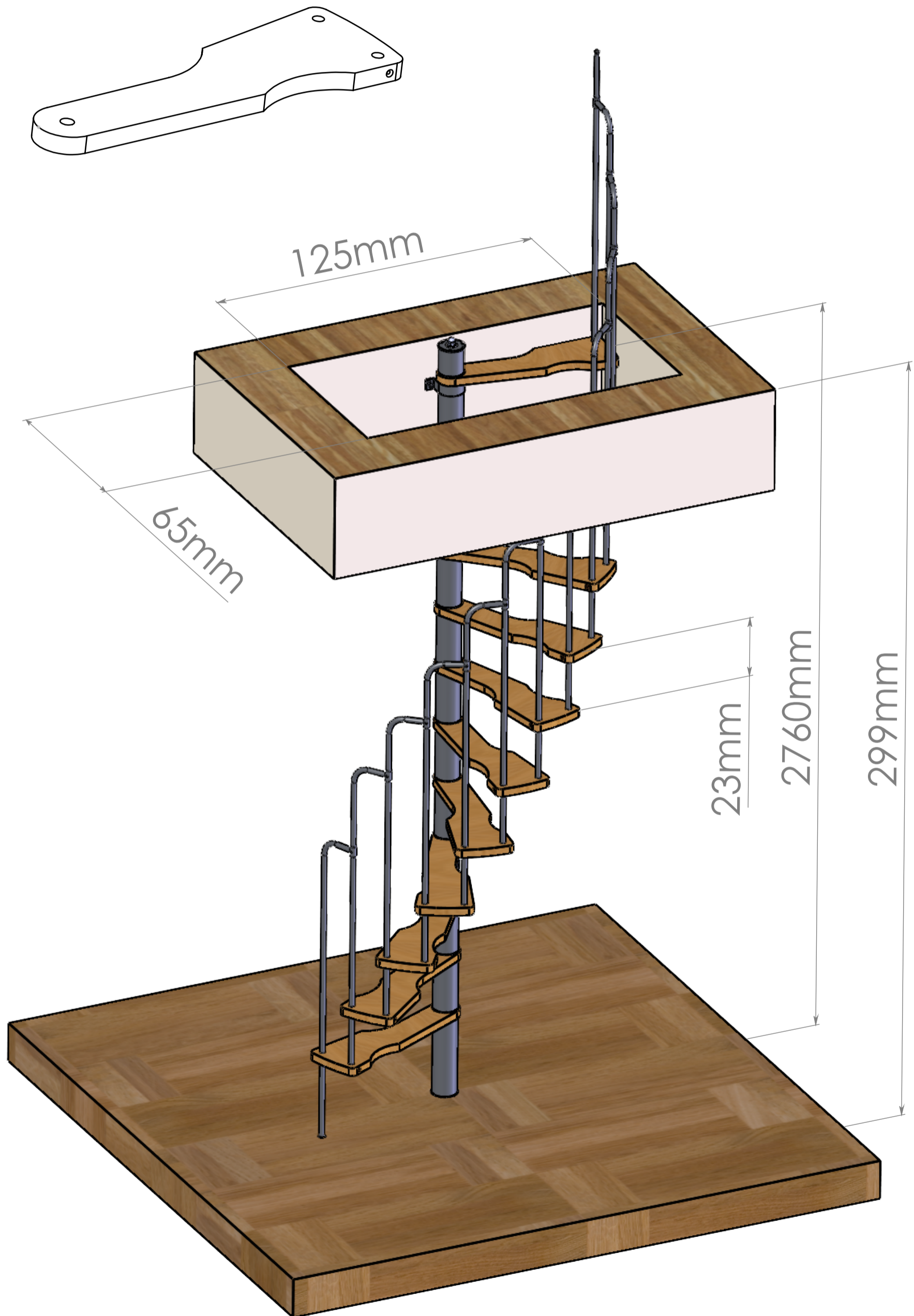

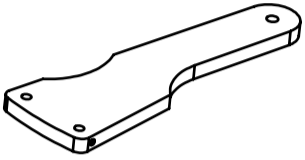

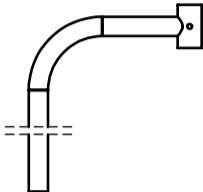

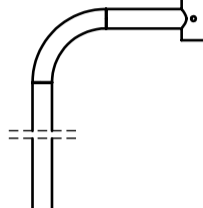
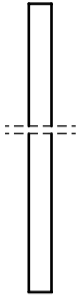
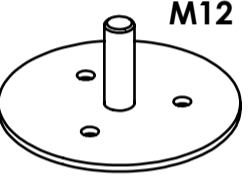
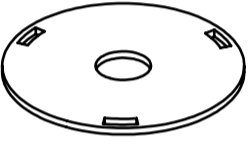

# Staircase Radius 120

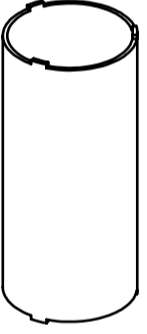
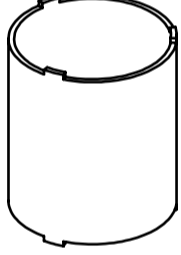

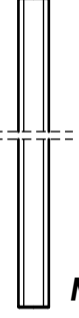
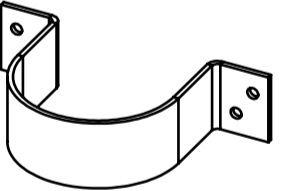
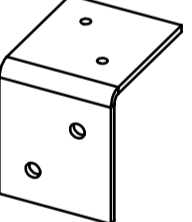
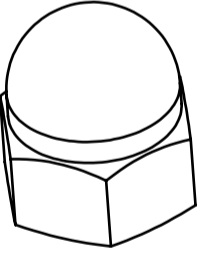
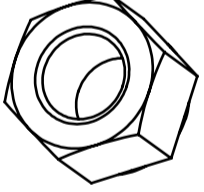
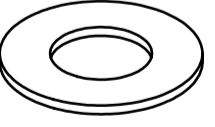
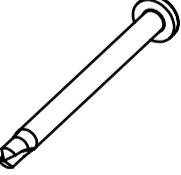
# Bill of materials

<p>① x12      662x210x30 mm</p> 	<p>② x1      <math>\phi</math> 18x1191 mm</p> 	<p>③ x11      <math>\phi</math> 18x1221 mm</p> 	<p>④ x1      <math>\phi</math> 18x1180 mm</p> 
<p>⑤ x1      <math>\phi</math> 96x40 mm</p> 	<p>⑥ x25      <math>\phi</math> 96x3 mm</p> 	<p>⑦ x1      <math>\phi</math> 80x3 mm</p> 	<p>⑧ x1      <math>\phi</math> 89x300 mm</p> 
<p>⑨ x11      <math>\phi</math> 89x194 mm</p> 	<p>⑩ x1      <math>\phi</math> 89x100 mm</p> 	<p>⑪ x2      <math>\phi</math> 20x997 mm</p> 	<p>⑫ x1      M20x997 mm</p> 
<p>⑬ x1      40x97x160 mm</p> 	<p>⑭ x1      50x60x60 mm</p> 	<p>⑮ x1      M20</p> 	<p>⑯ x1      M20</p> 
<p>⑰ x1      M20x27x3 mm</p> 	<p>⑱ x10      <math>\phi</math> 6.3x60 mm</p> 	<p>⑲ x24      <math>\phi</math> 6.3x38 mm</p> 	<p>⑳ x2      <math>\phi</math> 4x25 mm</p> 
<p>㉑ x12      <math>\phi</math> 4.2x13 mm</p> 	<p>㉒ x10      <math>\phi</math> 10x60 mm</p> 	<p>㉓ x24      <math>\phi</math> 10x60 mm</p> 	<p>㉔ x1      <math>\phi</math> 10x60 mm</p> 

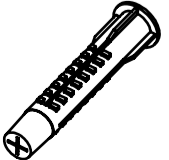
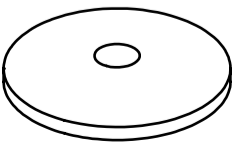
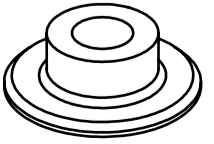
# STEP 1

Quantity:

1x 5

1x 7

3x 18

3x 22

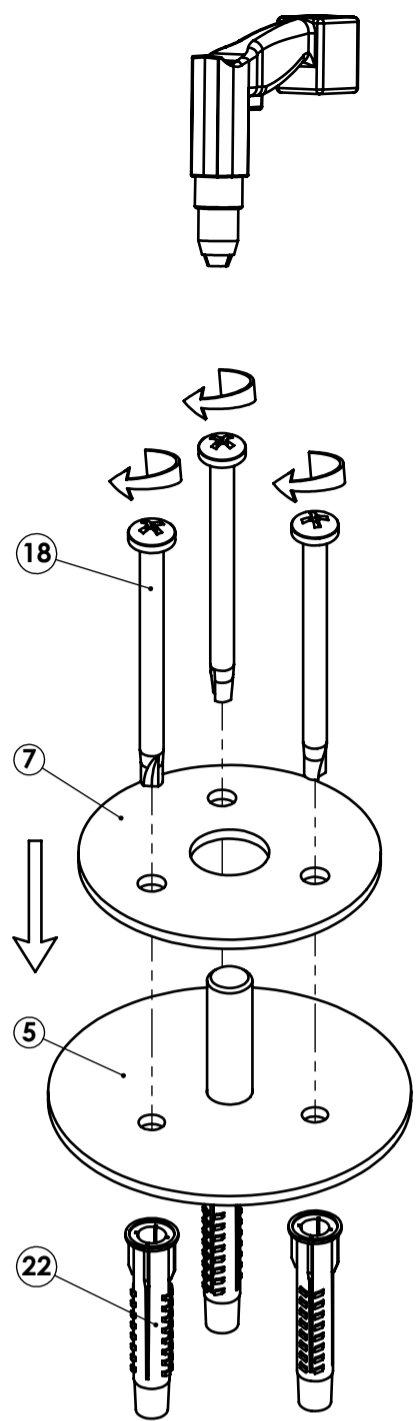

# STEP 2

Quantity:

12x 1

24x 6

1x 8

12x 9

2x 11

1x 12

1x 16

1x 17

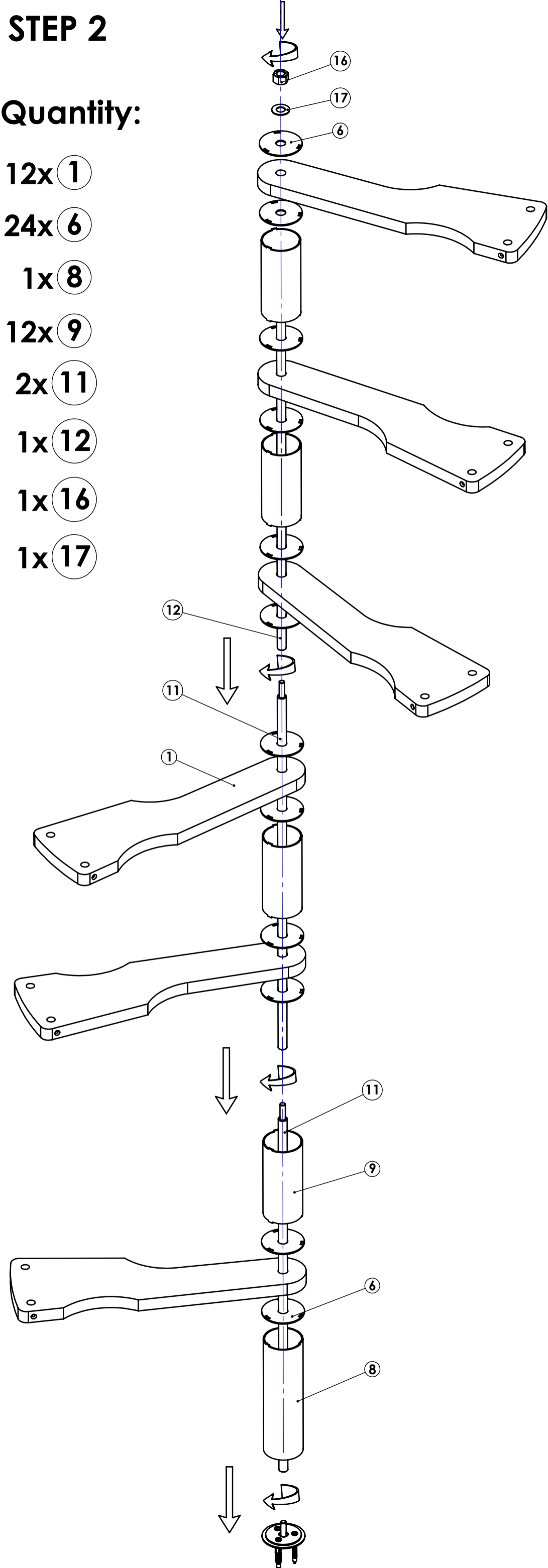

# STEP 3

Quantity:

1x 6

1x 10

1x 15

1x 17

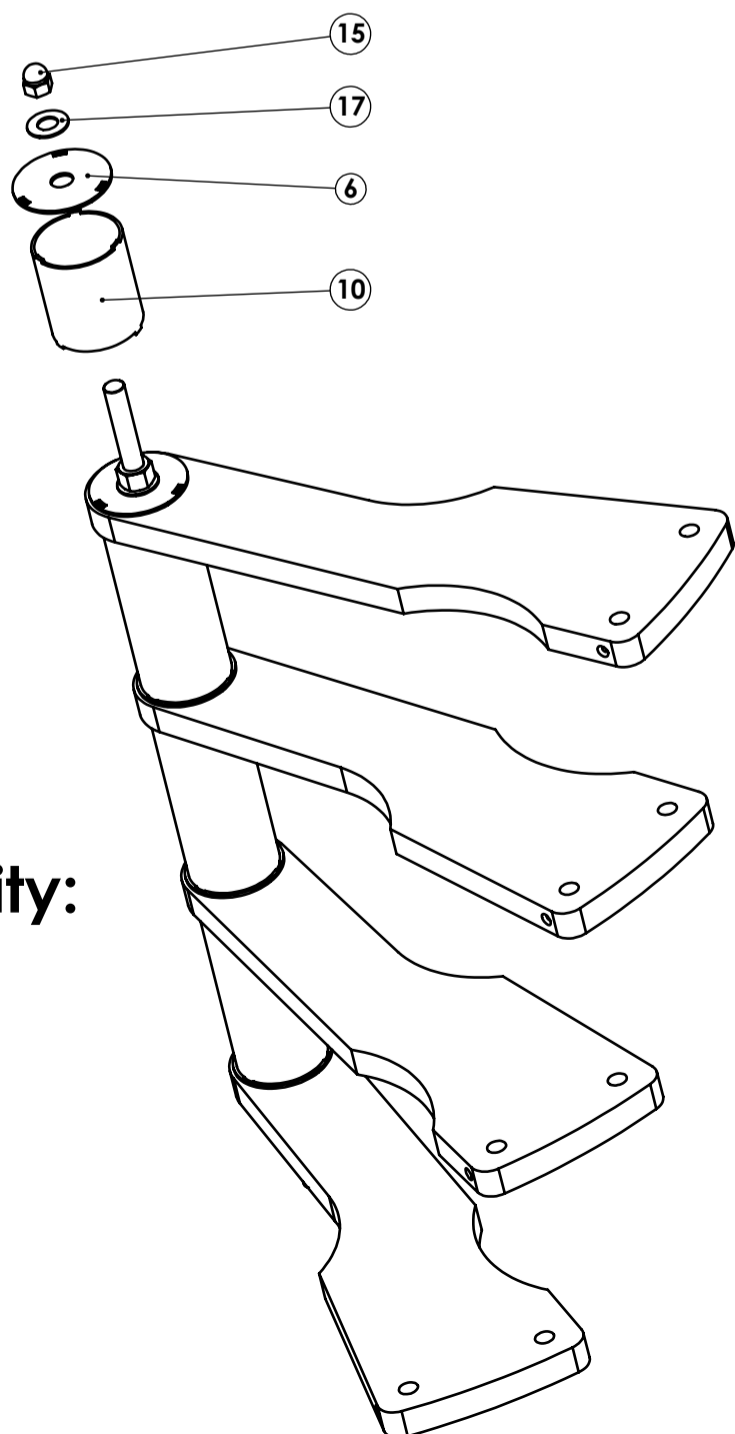

# STEP 4

Quantity:

1x 12

4x 18

4x 22

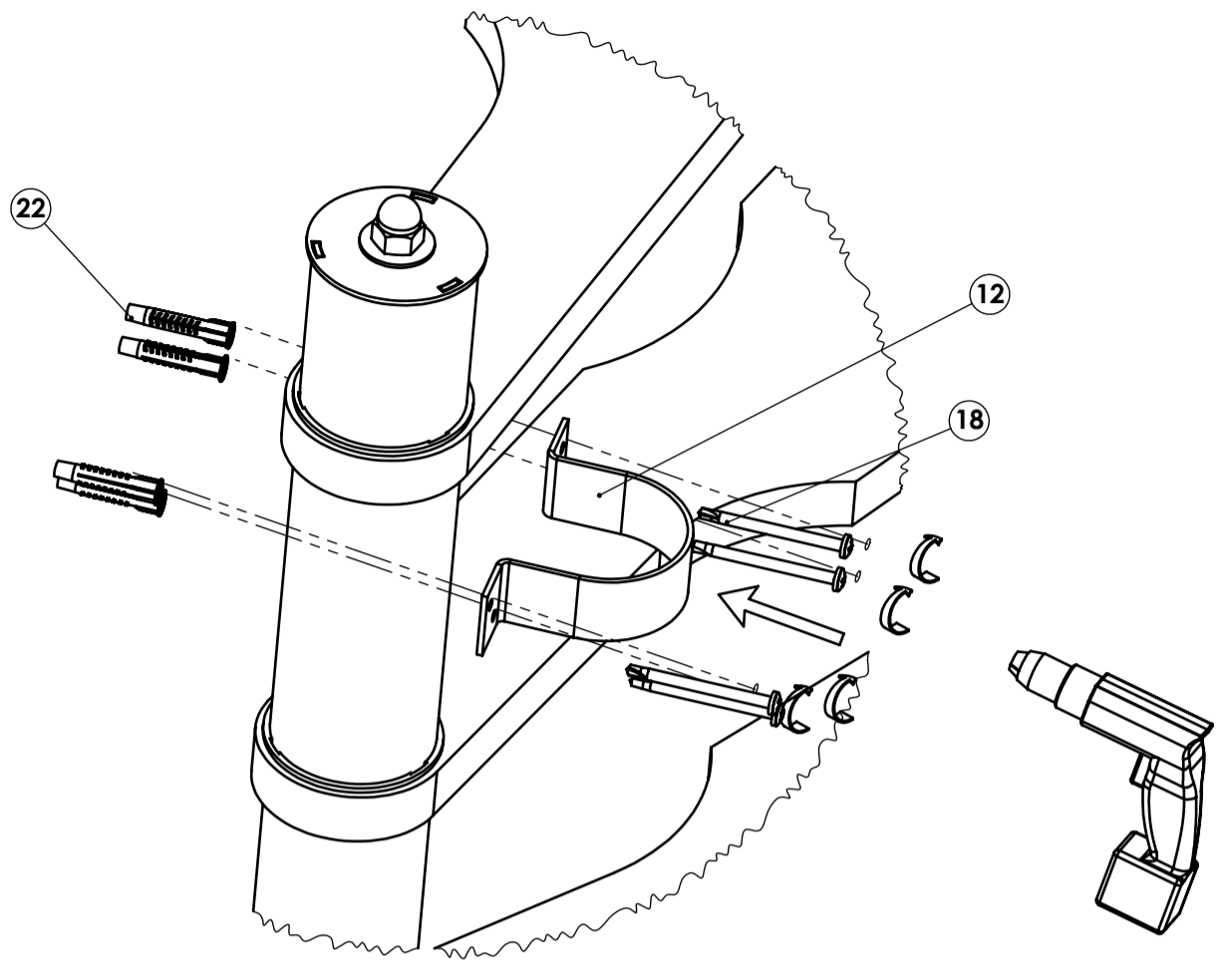

# STEP 5

Quantity:

1x 2

11x 3

1x 4

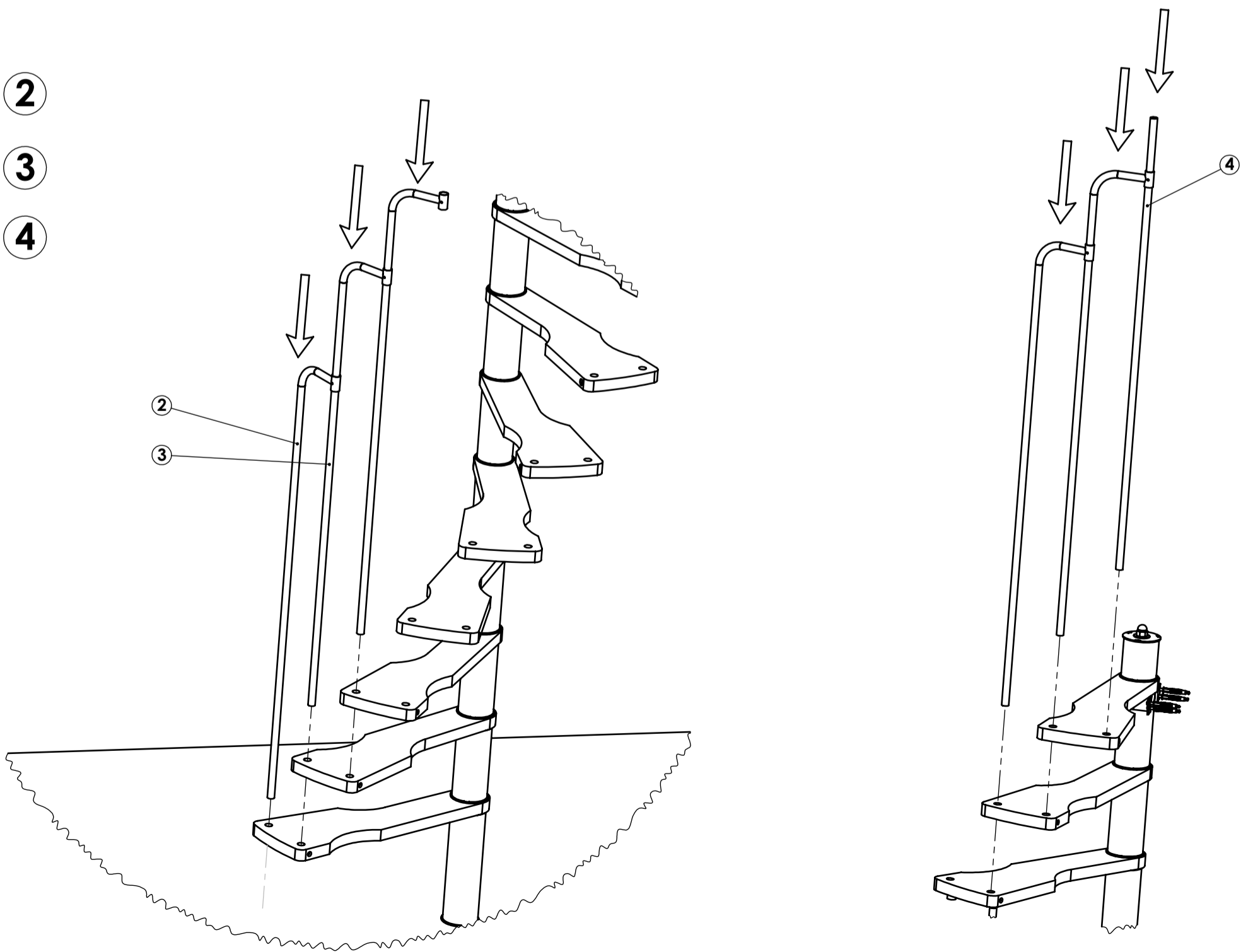

# STEP 6

Quantity:

24x 19

24x 23

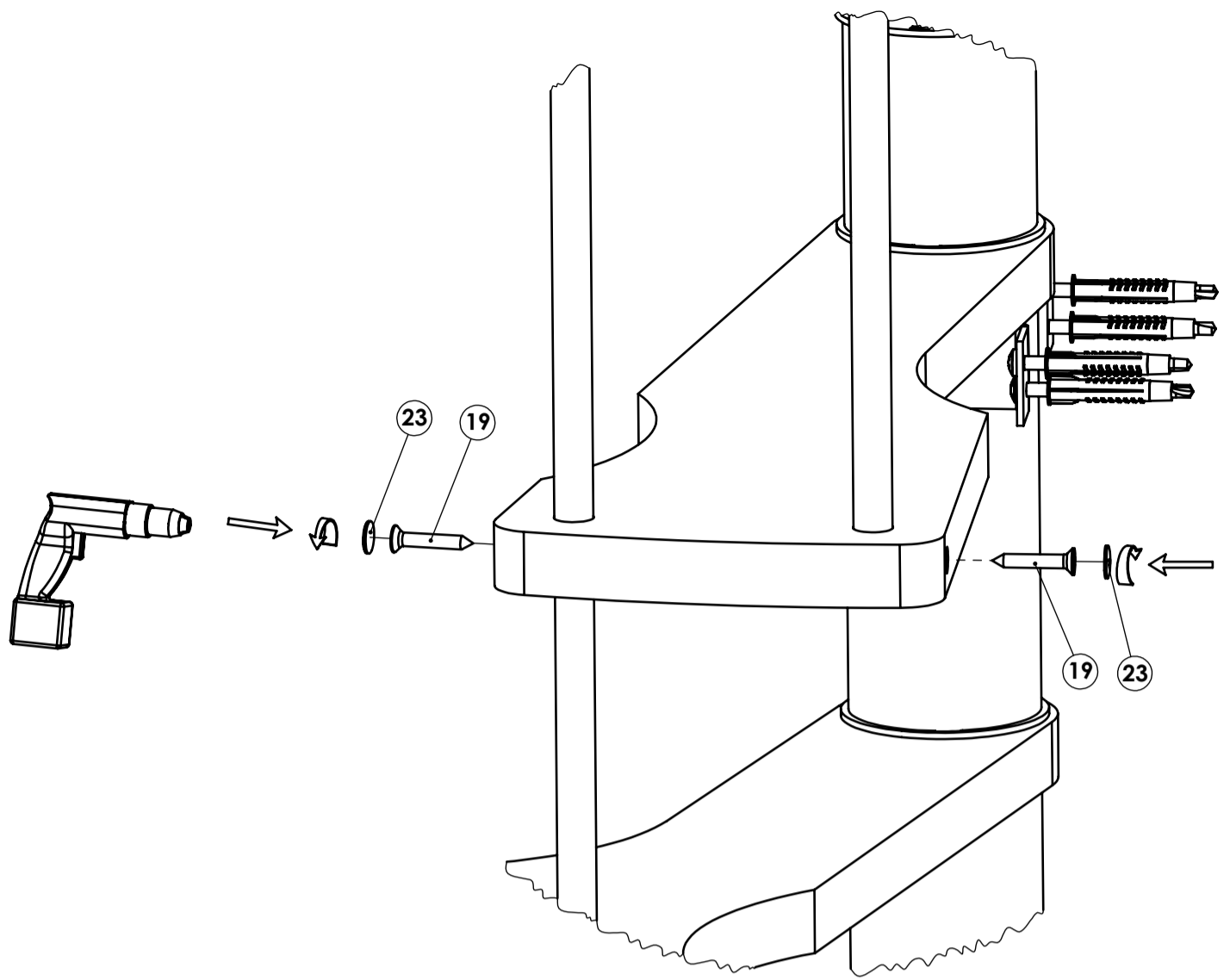

# STEP 7

Quantity:

1x 14

2x 17

2x 19

2x 22

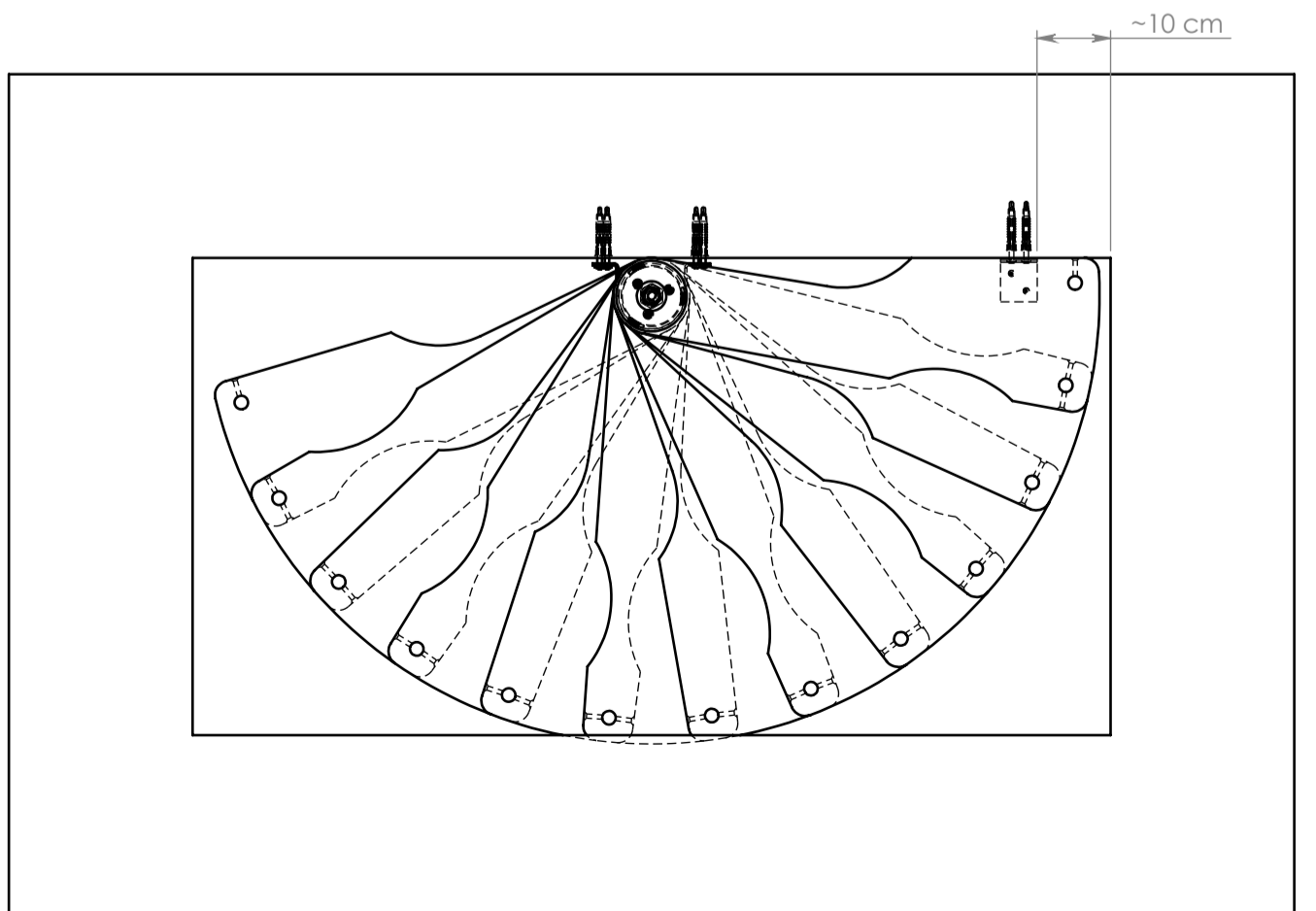
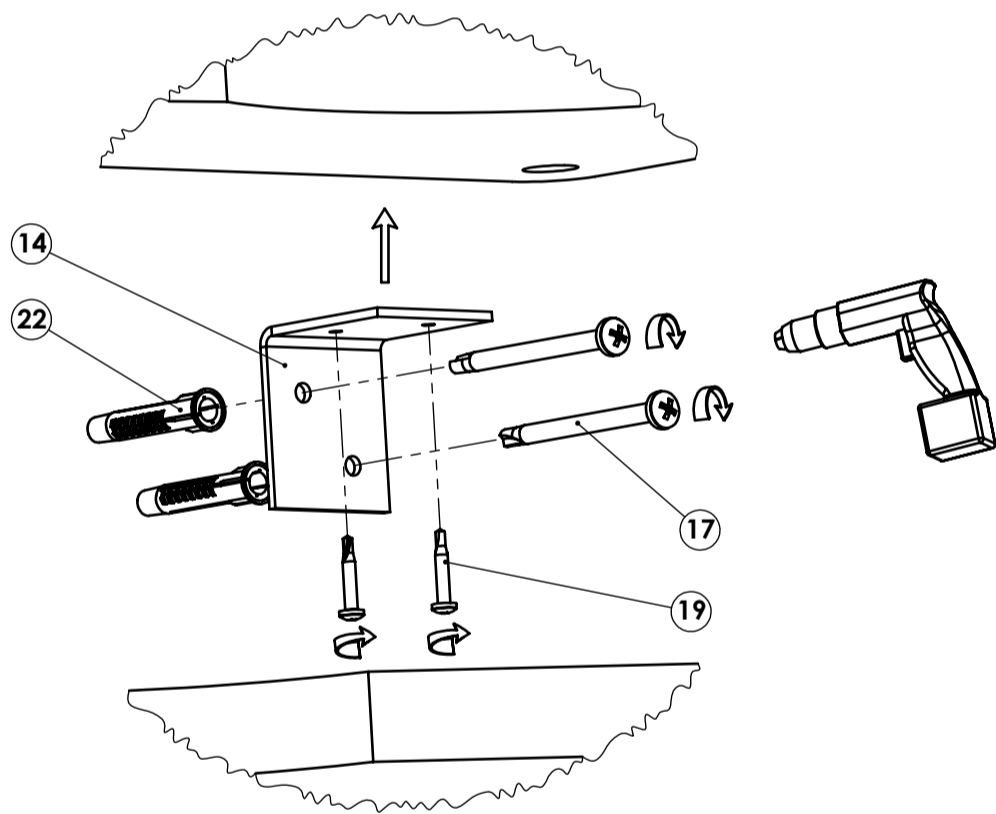

# STEP 7

Quantity:

1x 18

1x 22

1x 24

